

# T-TECH

## HSSEPM THREAD MILLING CUTTERS STANDARD RANGE

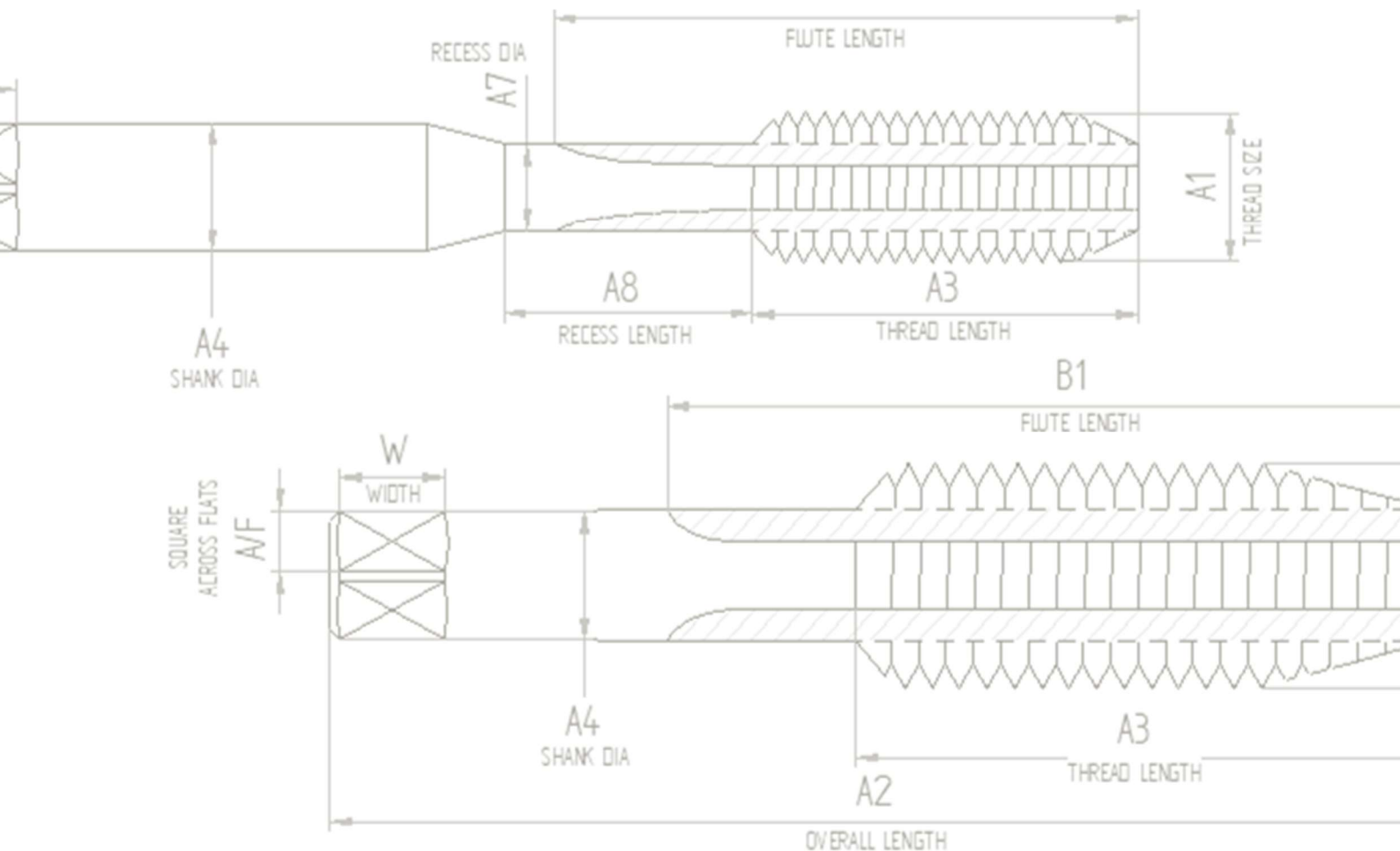

**T-TECH TOOLING LTD**

STANDARD RANGE HSSEpm THREAD MILLING CUTTERS

ISO METRIC		L1	L2	Z	To Suit Thread Size:			
D1	D3 h6				Metric Coarse	Code No.	Metric Fine	Code No.
					3.00	6.00	40.0	10.0
3.40	6.00	40.0	10.0	2	M4,5 x 0,75	HTM-4575MM	M4,5 x 0,50	HTM-4505MM
4.00	6.00	60.0	11.0	3	M5,0 x 0,80	HTM-5008MM	M5,0 x 0,50	HTM-5005MM
4.00	6.00	60.0	11.0	3	M6,0 x 1,00	HTM-6010MM	M6,0 x 0,75	HTM-6075MM
5.50	6.00	60.0	13.0	3	M8,0 x 1,25	HTM-8125MM	M8,0 x 1,00	HTM-8010MM
7.00	10.00	70.0	16.0	4	M10 x 1,50	HTM-1015MM	M10 x 1,25	HTM-1125MM
9.00	10.00	80.0	22.0	4	M12 x 1,75	HTM-2175MM	M12 x 1,25	HTM-2125MM
9.00	10.00	80.0	22.0	4	M14 x 2,00	HTM-1420MM	M14 x 1,50	HTM-1415MM
9.00	10.00	80.0	22.0	4	1,00 SERIES	HTM-9010MM	0,75 SERIES	HTM-9075MM
12.00	12.00	85.0	30.0	5	M16 x 2,00	HTM-1620MM	M16 x 1,50	HTM-1615MM
14.00	14.00	90.0	30.0	5	M18 x 2,50	HTM-1825MM		
14.00	14.00	90.0	30.0	5	M20 x 2,50	HTM-2025MM	M20 x 1,50	HTM-2015MM
19.00	20.00	100.0	38.0	6	M24 x 3,00	HTM-2430MM	M24 x 2,00	HTM-2420MM
19.00	20.00	100.0	38.0	6	M30 x 3,50	HTM-3035MM		
25.00	25.00	120.0	50.0	5	M36 x 4,00	HTM-3640MM	M30 x 2,00	HTM-3020MM
25.60	20.00	135.0	75,0*	5	M33 x 3,50	HTMR-3335MM		
25.60	20.00	135.0	75,0*	5	M36 x 4,00	HTMR-3640MM		
25.60	20.00	135.0	75,0*	6	2,00 SERIES	HTMR-2562MM	M30 x 2,00	HTMR-3020MM
25.60	20.00	135.0	75,0*	6	3,00 SERIES	HTMR-2563MM		

BSP / NPS		L1	L2	Z	To Suit Thread Size:			
D1	D2 h6				BSP	Code No.	NPS	Code No.
					7.00	10.00	70.0	16.0
9.00	10.00	80.0	22.0	4	1/4" x 19	HTM-1419G	1/4" x 18	HTM-1418N
9.00	10.00	80.0	22.0	4	3/8" x 19	HTM-3819G	3/8" x 18	HTM-3818N
14.00	14.00	90.0	30.0	5	1/2" x 14	HTM-1214G	1/2" x 14	HTM-1214N
14.00	14.00	90.0	30.0	5	5/8" x 14	HTM-5814G	5/8" x 14	HTM-5814N
14.00	14.00	90.0	30.0	5	3/4" X 14	HTM-3414G	3/4" x 14	HTM-3414N
19.00	20.00	100.0	38.0	6	1" x 11	HTM-1211G	1" x 11,5	HTM-1115N
25.60	20.00	135.0	75,0*	6	1"+	HTMR-1211G	1"+	HTMR-1115N

\* All 'HTMR' cutters have a thread length of 36mm, capable of producing a thread depth of 75mm.  
HSS3 refers to our code for ASP2030™ (8,5% Co) Powder metallurgy HSS

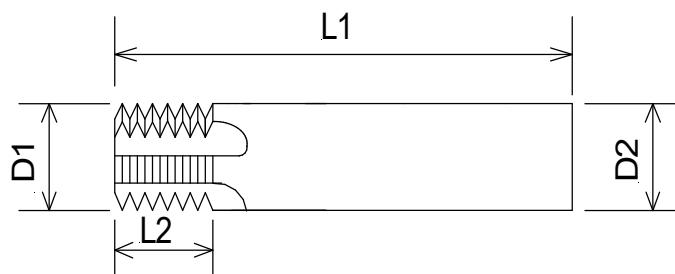

**T-TECH TOOLING LTD**

STANDARD RANGE HSSEpm THREAD MILLING CUTTERS

UNIFIED					To Suit Thread Size:			
D1	D2 h6	L1	L2	Z	UNC	Code No.	UNF	Code No.
3.00	6.00	40.0	10.0	2			No.8	HTM-0836UN
3.00	6.00	40.0	10.0	2	No. 8	HTM-0832UN		
3.40	6.00	40.0	10.0	2	No.10	HTM-1024UN	No.10	HTM-1032UN
4.00	6.00	60.0	11.0	3	1/4"	HTM-1420UN	1/4"	HTM-1428UN
5.50	6.00	60.0	13.0	3	5/16"	HTM-3118UN	5/16"	HTM-3124UN
7.00	10.00	70.0	16.0	4	3/8"	HTM-3816UN	3/8"	HTM-3824UN
7.00	10.00	70.0	16.0	4	7/16"	HTM-4314UN		
9.00	10.00	80.0	22.0	4	1/2"	HTM-1213UN	7/16"	HTM-4320UN
9.00	10.00	80.0	22.0	4	9/16"	HTM-5612UN	1/2"	HTM-1220UN
12.00	12.00	85.0	30.0	5			9/16"	HTM-5818UN
12.00	12.00	85.0	30.0	5	5/8"	HTM-5811UN	5/8"	HTM-5818UN
14.00	14.00	90.0	30.0	5	3/4"	HTM-3410UN	3/4"	HTM-3416UN
14.00	14.00	90.0	30.0	5	7/8"	HTM-7809UN	7/8"	HTM-7814UN
19.00	20.00	100.0	38.0	6	1"	HTM-1008UN	1"	HTM-1012UN
19.00	20.00	100.0	38.0	6	1 1/8"	HTM-1127UN	1 1/8"	HTM-1012UN
19.00	20.00	100.0	38.0	6	1 1/4"	HTM-1127UN	1 1/4"	HTM-1012UN
25.00	25.00	120.0	50.0	5	1 1/4"	HTME-1127UN		
25.00	25.00	120.0	50.0	5	1 3/8"+	HTM-1386UN	1 3/8"+	HTM-3812UN
25.60	20.00	135.0	75,0*	5	1 1/4"	HTMR-1147UN		
25.60	20.00	135.0	75,0*	5	1 3/8"	HTMR-1127UN		
25.60	20.00	135.0	75,0*	5	1 1/2"+	HTMR-1386UN		
25.60	20.00	135.0	75,0*	6	8 UN SERIES	HTMR-2568UN		
25.60	20.00	135.0	75,0*	6	12 UN SERIES	HTMR-2512UN	1 1/8"+	HTMR-1112UN

\* All 'HTMR' cutters have a thread length of 36mm, capable of producing a thread depth of 75mm.  
HSS3 refers to our code for ASP2030™ (8,5% Co) Powder metallurgy HSS

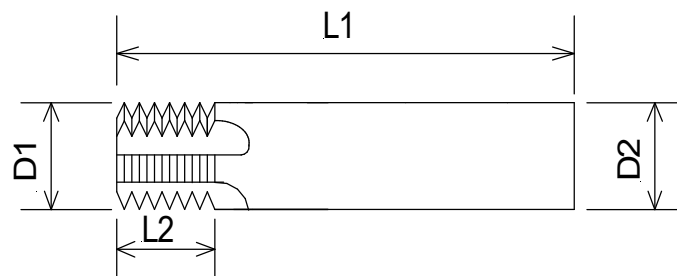

**T-TECH TOOLING LTD**

STANDARD RANGE HSSEpm THREAD MILLING CUTTERS

BSW / BSF		To Suit Thread Size:						
D1	D2 h6	L1	L2	Z	BSW	Code No.	BSF	Code No.
3.40	6.00	40.0	10.0	2	3/16"	HTM-1824WF	3/16"	HTM-1832WF
4.00	6.00	60.0	11.0	3	1/4"	HTM-1420WF	1/4"	HTM-1426WF
5.50	6.00	60.0	13.0	3	5/16"	HTM-3118WF	5/16"	HTM-3122WF
7.00	10.00	70.0	16.0	4	3/8"	HTM-3816WF	3/8"	HTM-3820WF
7.00	10.00	70.0	16.0	4	7/16"	HTM-4314WF	7/16"	HTM-4318WF
9.00	10.00	80.0	22.0	4	1/2"	HTM-1212WF	1/2"	HTM-1216WF
9.00	10.00	80.0	22.0	4	9/16"	HTM-5612WF	9/16"	HTM-5616WF
9.00	10.00	80.0	22.0	4	26 WF	HTM-9026WF		
12.00	12.00	85.0	30.0	5	5/8"	HTM-5811WF	5/8"	HTM-5814WF
14.00	14.00	90.0	30.0	5	3/4"	HTM-3410WF	3/4"	HTM-3412WF
14.00	14.00	90.0	30.0	5	7/8"	HTM-7809WF	7/8"	HTM-7811WF
14.00	14.00	90.0	30.0	5			1"	HTM-1010WF
19.00	20.00	100.0	38.0	6	1"	HTM-1008WF		
19.00	20.00	100.0	38.0	6	1 1/8-1 1/4	HTM-1187WF	1 1/8"	HTM-1189WF
19.00	20.00	100.0	38.0	6			1 1/4"	HTM-1149WF
25.00	25.00	120.0	50.0	5	1 3/8"+	HTM-1386WF	1 1/4"+	HTME-1149WF
26.60	20.00	135.0	75.0*	5	1 1/4"	HTMR-1147WF	1 1/4"+	HTMR-1149WF
26.60	20.00	135.0	75.0*	5	1 3/8"+	HTMR-1386WF	1 3/8"+	HTMR-1388WF

NPT / BSPT		To Suit Thread Size:						
D1 Small End	D2 h6	L1	L2	Z	NPT	Code No.	BSPT	Code No.
7.20	10.00	49.0	10.0	4	1/8"	HTM-1827NT	1/8"	HTM-1828BT
9.00	10.00	55.0	15.5	4	1/4"	HTM-1418NT	1/4"	HTM-1419BT
14.60	16.00	70.0	20.0	5	1/2"	HTM-1214NT	1/2"	HTM-1214BT
23.20	25.00	100.0	28.0	6	1"	HTM-1115NT	1"	HTM-1011BT

\* All 'HTMR' cutters have a thread length of 36mm, capable of producing a thread depth of 75mm.

HSS3 refers to our code for ASP2030™ (8,5% Co) Powder metallurgy HSS.

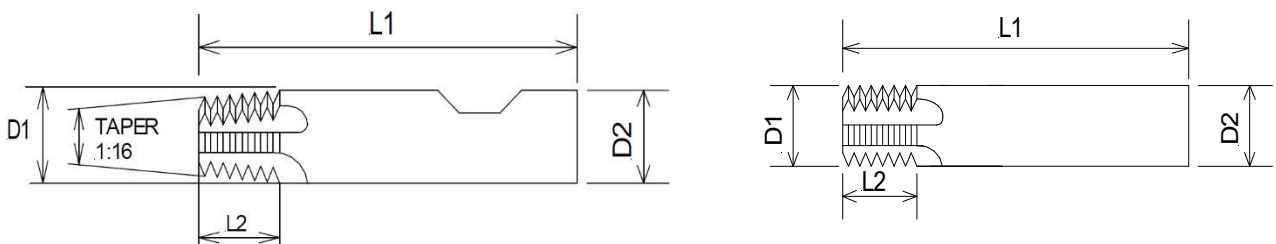

**T-TECH TOOLING LTD**